

perfect

BALANCE

Airetrak



Patented

Set it and forget it!

The Tamarack Airetrak control will earn Energy Star points, meet ASHRAE 62.2 standards and improve indoor air quality.

The Airetrak is used in lieu of a regular wall switch for the bath fan. It sets the fan to operate intermittently throughout the day at variable speeds. In addition, it works as a regular switch that turns the fan on high speed for 20 minutes, then resumes the programmed cycle.

The Airetrak is easy to install, has a lithium battery to hold programming during power failures and comes with a 1-year manufacturer warranty.

Please call us at Tamarack for contractor pricing and availability.



320 Main Street • Buzzards Bay, Ma 02532
508-759-4660 / 800-222-5932 / Fax 508-759-6001

Airetrak

Patented Airetrak Fan Control is quick, easy to install, and economical!
Makes standard bath fans ASHRAE 62.2 compliant!

Specifications

Input120 VAC 60 Hz
Maximum Power Output180 Watts
Battery BackupLithium
Dimensions3 5/8" x 1 5/8"

Features

Air Flow: Rate is adjustable from 40% to 100% of fan capacity. The installer can select from 16 different settings based on home size, occupancy and other field conditions.

Built-in Timer: Programmed on installation to operate the ventilation equipment in 5 minute increments (5, 10, 15, etc.) during a 12 or 24 hour cycle. With a lithium battery backup, the unit holds its settings even after a power failure.

Boost Feature: To activate the boost feature, simply press the boost button and the fan will operate at full speed for 20 minutes, then automatically resume its programmed cycle.

Airetrak-CD: Needs no programming. Runs constantly at the selected speed. boost button increases the flow to full speed. Pressing it a second time drops the flow back to the background rate.

Some ventilation equipment should not be used with a solid state speed control. Please check with the manufacturer.

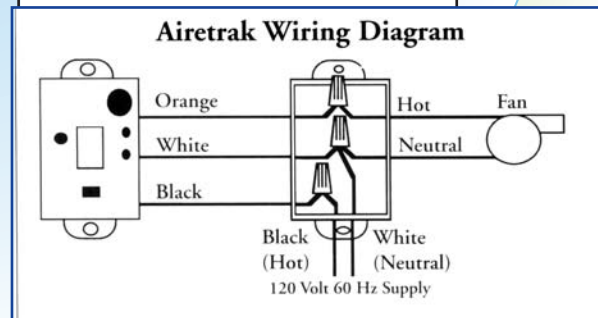
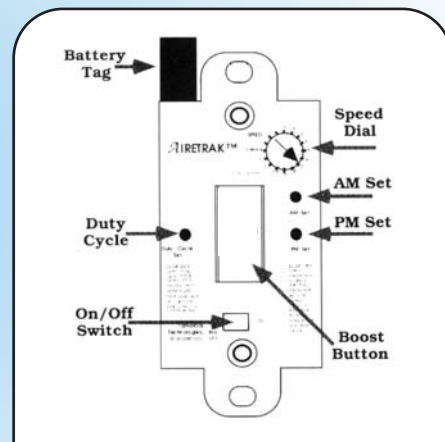

P/N ATK.2



Tamarack
Technologies, Inc.

Ventilation Solutions
www.tamtech.com

320 Main Street • Buzzards Bay, Ma 02532
508-759-4660 / 800-222-5932 / Fax 508-759-6001