

HV1450 EVERGREEN

WHOLE HOUSE COMFORT VENTILATOR PRODUCT MANUAL & INSTALLATION GUIDE



Please note the serial number, date of purchase, and the point of purchase below for handy reference. The serial number is located on a label affixed to the HV1450 next to the junction/utility box.

Serial Number _____

Date of Purchase _____

Point of Purchase _____

Unpacking your HV1450:

When you have unpacked your HV1450 carefully you will find the following:

One (1) Whole House Comfort Ventilator
One (1) Damper
One (1) Metal electrical box cover with (2) screws
One (1) White Metal grille w/(6) screws

Four (4) Hex Standoffs
Four (4) Flat Washers
Four (4) Philips Head Screws
Four (4) Lock Nuts

What the HV1450 Whole House Comfort Ventilator Does:

The HV1450 is used to assist the natural cooling process in the house. When the outside temperature drops below the inside temperature, the cooler outside air can be used to cool the house. The HV1450 will pull the cooler air from the outside, through the house, up into the attic and push the hot air outside. The HV1450 is a fan product and will not cool the house below the outside air temperature or create a noticeable breeze. The HV1450 can be used any time, for as long as needed, to cool or change the air in the house.

The Best Location for your HV1450: The HV1450 should be located as central as possible to the area that you want to cool. Above a central hallway or at the top of a stairwell provide the best airflow. The fan can also be mounted vertically, exhausting through a knee wall into an under-the-attic space. Cooler outside air should be able to move through the window, the space that needs to be cooled, and exhaust out through the fan into the attic.

► Read all instructions before installing

- Make sure that there aren't any pipes, wires, rafters or air conditioning or heating ducts running through the space where the HV1450 will be installed and that the damper will open into an unoccupied area.
- Make sure that you have adequate exhaust area out of your attic. This can be accomplished with a combination of roof, ridge or gable end vents. The HV1450 requires a minimum of 4 square feet of attic venting.
- Some state and local electrical code require fan products to be installed by a licensed electrician. Check with your local code officials before installation.

READ AND SAVE THESE INSTRUCTIONS

⚡ WARNING: TO REDUCE THE RISK OF FIRE, ELECTRIC SHOCK, OR INJURY TO PERSONS, OBSERVE THE FOLLOWING:

- ✓ Use this unit in the manner intended by the manufacturer. If you have any questions, contact the manufacturer.
- ✓ Before servicing or cleaning unit, switch power off at service panel and lock service panel to prevent power from being switched on accidentally. When the service disconnecting cannot be locked, securely fasten a prominent warning device, such as a tag, to the service panel.
- ✓ When cutting or drilling into wall or ceiling, do not damage electrical wiring or other hidden utilities.
- ✓ Never place a switch where it can be reached from a tub or shower.
- ✓ Do not use this fan over a tub or shower.
- ✓ Do not use this fan over cooking appliances.

✓ **WARNING:** To Reduce The Risk of Fire or Electric Shock, Do Not Use This Fan With Any Solid-State Speed Control Device.

CAUTION: For General Ventilation Use Only. Do Not Use To Exhaust Hazardous Or Explosive Materials And Vapors

CAUTION: This unit has an unguarded impeller. Do Not Use in Locations Readily Accessible to People or Animals.



320 Main Street • Buzzards Bay, Ma 02532
508-759-4660 / 800-222-5932 / Fax 508-759-6001

Installation

Tools and supplies needed (Not Included): You will need the following items: two pieces of 2x stock to match your existing framing, a saw to cut the hole in the ceiling, a hammer or screw gun to attach the blocking to the existing joists, a Phillips head screw driver to attach the grille, weather strip material and low expansion spray foam sealant.

1. Cut a hole in the ceiling under where the HV1450 will be installed. Suggested methods for making the proper sized hole in the ceiling are; cut a pilot hole under where the fan will be installed. Cut toward the edge to find the joist pattern and layout the fan opening on the ceiling; OR the four corners of the opening from the attic side and draw a line between each of the four corners to layout the fan opening; OR use a stud finder to locate the joists, cut a template from the fan packaging material and use the template to layout the fan opening. The dimensions of the hole should be no greater than 22-1/2" x 14-1/2". This will allow for the grille to cover the exposed sheetrock edges.

2. The fan housing will fit either 16" or 24" on-center framing. Cut two pieces of 2x stock (2x6 or 2x8 etc.) of the same dimension as the existing joists. Add these pieces of framing to form a box between the joists.

3. Install foam weatherstrip material (not supplied) on the top of the joists and added framing. Caulk the joist between the ceiling and the 2x stock. Some types of ceilings are spaced away from the joists. Any gap between the 2x's and the ceiling should be sealed prior to final installation. Use a low expansion spray foam sealant (not supplied).

4. Insert the threaded end of the hex standoffs through the hole in the housing. From the backside of the housing secure each standoff with a locknut. Place the damper on the housing with the label side facing the attic space. Pass the standoffs through the holes in the damper. Secure the damper in place with a flat washer and phillips head screw. The damper should move freely about the standoffs.

5. Set the HV1450 on the gasket with the damper facing into the attic. The housing will fit the framing with the mounting flanges over lapping the joists.

6. If desired, secure the HV1450 to the top of the joists using wood screws (not provided). When fastening the mounting flange to the joists, care should be taken that all screws are tightened evenly.

7. Wire the HV1450 as shown in the wiring diagram. It is recommended wiring of the HV1450 be done by licensed electrician.

8. Install grille (6 screws included) on the ceiling below the fan.

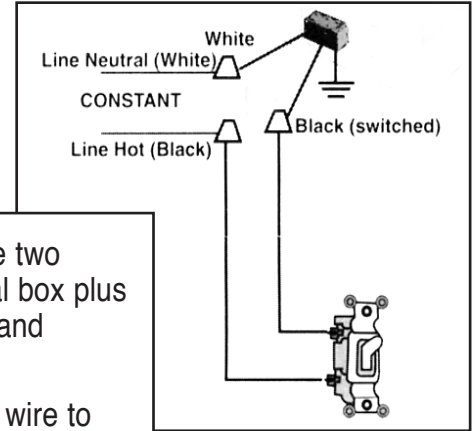

WIRING: There are two wires in the electrical box plus the ground: WHITE and BLACK.

- Connect the White wire to Line Neutral
- Connect the BLACK wire to a Switched Hot Feed or the output leg of your switch.
- Connect the ground wire to the screw in the electrical box

SPECIFICATIONS:

Voltage . . . 115VAC 60Hz
Power78 Watts
Airflow1450 CFM
Weight13 Lbs.
Rough Opening
.14 1/2" x 22 1/2"
Grille Outside Dimensions
.15 3/4" x 25 3/4"
Grille ColorWhite

CARE: All the motors are permanently sealed and do not require oiling. To keep dirt, dust and debris from fan, we recommend you periodically remove the grille from within the living space and dust the fan blades. Please remember to make sure that the fan is OFF before dusting the fan blades.

TROUBLE SHOOTING: The most common problem with the HV1450 is caused by incorrect wiring. Before you check anything else make sure WHITE wire in HV1450 is connected to 115 VAC line neutral: BLACK wire is connected to a switch that will make it hot when the switch is closed.

LIMITED WARRANTY IF, WITHIN THE PERIOD OF 90 DAYS FROM DATE OF PURCHASE THE HV1450 (THE PRODUCT) IS DEFECTIVE OR MALFUNCTIONS IN NORMAL HOME USE, TAMARACK WILL REPAIR OR REPLACE THE HV1450 AT ITS DISCRETION WITHOUT CHARGE FOR LABOR OR MATERIALS. CUSTOMER IS RESPONSIBLE FOR SHIPPING CHARGES. NOTE: SOME STATE CODES REQUIRE FANS TO BE HARD WIRED. HARDWIRING THE HV1450 WILL NOT VOID WARRANTY PROVIDING THE WIRING IS PERFORMED BY A LICENSED ELECTRICIAN.

CONDITIONS, EXCLUSIONS, AND LIMITATIONS -THIS WARRANTY IS SUBJECT TO THE FOLLOWING CONDITIONS, EXCLUSIONS AND LIMITATIONS. THIS WARRANTY DOES NOT COVER PROBLEMS RESULTING FROM INSTALLATION, OPERATION OR MAINTENANCE THAT HAS BEEN UNDERTAKEN OTHER THAN IN ACCORDANCE WITH THE INSTRUCTIONS. THIS WARRANTY DOES NOT COVER PROBLEMS RESULTING FROM DEFECTS IN OR CAUSED BY ASSOCIATED EQUIPMENT (FURNACES, SOLARIA, ETC.) ; FROM REPAIRS OR MODIFICATIONS ATTEMPTED BY PERSONS OTHER THAN TAMARACK.; FROM ABUSE, ACCIDENTAL OR SHIPPING DAMAGE, ACTS OF GOD. THIS WARRANTY DOES NOT APPLY TO THE PRODUCT USED OUTSIDE THE UNITED STATES, ITS TERRITORIAL POSSESSIONS AND CANADA. EXCEPT AS SET FORTH ABOVE, NO EXPRESS OR IMPLIED WARRANTY IS GIVEN OR AUTHORIZED BY TAMARACK. AND ALL OTHER SUCH WARRANTIES ARE EXPRESSLY DISCLAIMED. ANY WARRANTY OR MERCHANTABILITY OF FITNESS FOR ANY PARTICULAR PURPOSE SHALL BE LIMITED TO THE WARRANTY HEREUNDER. MOREOVER, ANY LIABILITY OF TAMARACK FOR THE PRODUCT SHALL BE LIMITED TO THE REPLACEMENT OF THE PRODUCT. IN NO EVENT SHALL TAMARACK BE LIABLE FOR ANY INCIDENTAL DAMAGES OR FOR ANY CONSEQUENTIAL PROPERTY OR COMMERCIAL DAMAGES, IRRESPECTIVE OF THE CAUSE THEREOF, OCCURRING EITHER DURING OR AFTER THE WARRANTY PERIOD. INCLUDING WITHOUT LIMITATION ANY DAMAGE TO ANY PART OF A BUILDING OR ITS CONTENTS. NOTE: SOME STATES DO NOT ALLOW THE EXCLUSION OR LIMITATION OF INCIDENTAL OR CONSEQUENTIAL DAMAGES AND SOME STATES DO NOT ALLOW LIMITATIONS ON HOW LONG AN IMPLIED WARRANTY LASTS, SO THE ABOVE LIMITATIONS OR EXCLUSIONS MAY NOT APPLY TO YOU. THIS WARRANTY GIVES YOU SPECIFIC LEGAL RIGHTS AND YOU MAY ALSO HAVE OTHER RIGHTS THAT VARY FROM STATE TO STATE.

PROOF OF PURCHASE REQUIRED.



320 Main Street • Buzzards Bay, Ma 02532
508-759-4660 / 800-222-5932 / Fax 508-759-6001