

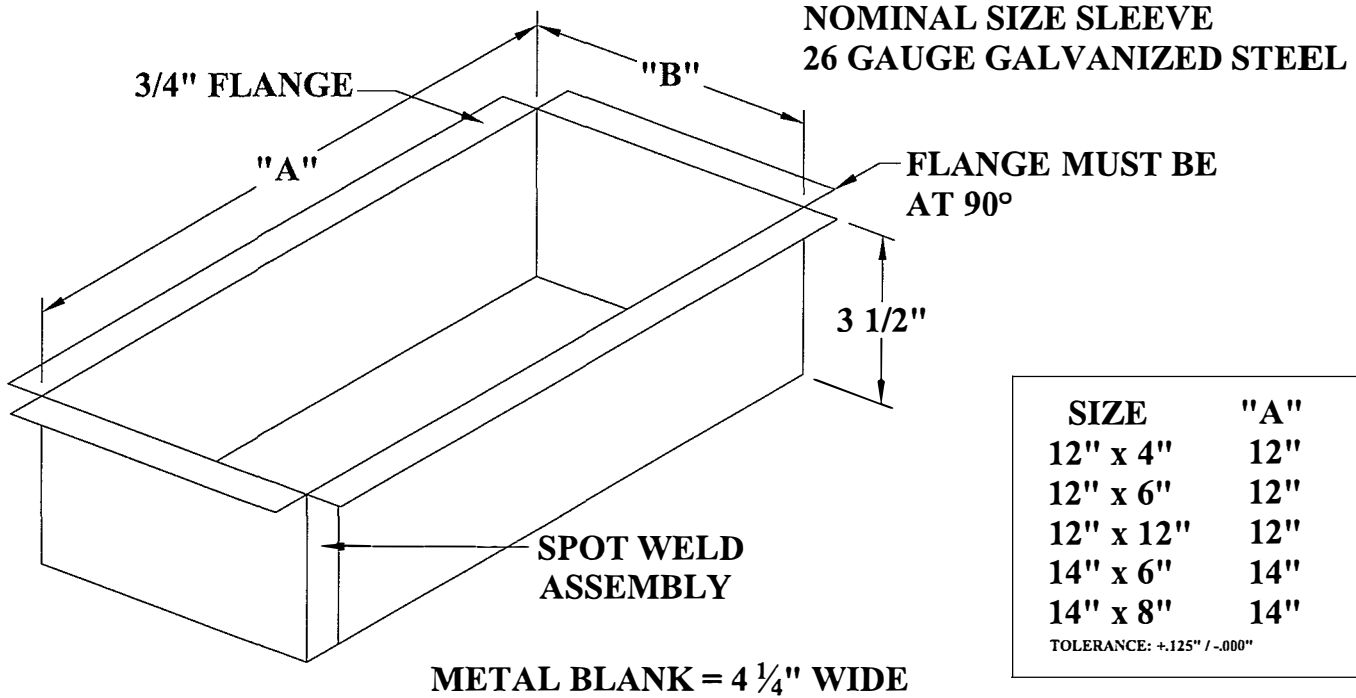

RETRO RAP

2 METAL SLEEVES FOR ASSEMBLY



UNDERSIZED SLEEVE (1/8" UNDERSIZED)

TOLERANCE +.000" / -.063"

THIS UNDERSIZED SLEEVE TO SLIDE SMOOTHLY INTO NOMINAL SIZE SLEEVE

26 GAUGE GALVANIZED STEEL
VERTICEL PANEL FITS IN THIS SLEEVE

