

**3400**

**5300**

**VENTURA**



**Whole House Fan**

**Installation and Operation Manual**



Thank you for your purchase!

Image: Ventura 5300

# INDEX

[FRONT PAGE](#)

[THEORY OF OPERATION](#)

[SAFETY INFORMATION](#)

[HANDLING INSTRUCTIONS](#)

[SUPPLIES INCLUDED](#)

[REQUIRED TOOLS AND SUPPLIES NOT INCLUDED](#)

[ELECTRICAL REQUIREMENTS](#)

[SYSTEM INSTALL GUIDE](#)

[INSTALLATION OF THE AIR-DOOR \(AD26\)](#)

[INSTALLATION OF THE DUCT](#)

[INSTALLATION OF WIRING AND CONTROL](#)

[PURCHASE OPTIONS \(not included\)](#)

[START-UP AND OPERATION](#)

[OPERATING TIPS](#)

[DTC CONTROLLER](#)

[FAN BOX BOARD](#)

[MAINTENANCE](#)

[GLOSSARY](#)

[TROUBLE SHOOTING](#)

[SPECIFICATIONS](#)

[AIRLAB RESULTS](#)

[ELECTRICAL SCHEMATICS](#)

## THEORY OF OPERATION

As a home heats up during the day, a large amount of heat is retained in its structure and contents. These materials give off their heat slowly and continue to heat the home's interior even if the outdoor temperature is comfortable. Homeowners are then forced to endure either uncomfortable hot indoor temperatures, or the expense of air conditioning. AirScape Sierra® and Ventura® whole house fans resolve this dilemma by exhausting hot indoor air out of, and drawing cool outdoor air into, the home.

Each of our fans has been designed for quiet and efficient operation. As such, we strongly recommend running this fan through the night to extract the maximum possible amount of heat from the home. This not only helps maintain a comfortable indoor temperature, but essentially “pre-cools” the home ahead of the next day's rise in temperature, which reduces, or can even eliminate, the need for traditional air conditioning.

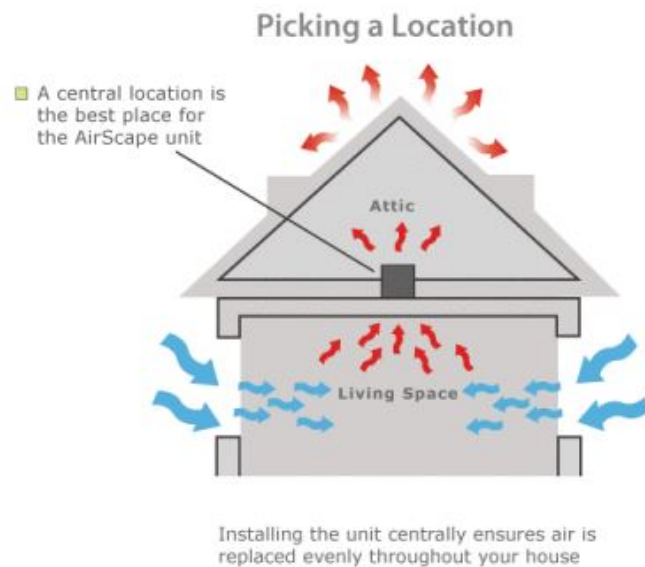

- Locate this fan in a central location away from windows that will be opened to promote an even replacement of air throughout the home and greater the cooling effect.
- Locate this fan at the highest point possible to exploit natural convection and help exhaust the hottest indoor air from the home.
- In a two-story home, the ideal location for this fan is typically in the open area at the top of the stairs.
- Avoid locating this fan in a narrow space or over hard flooring as the reflection of sound off of hard surfaces can amplify its perceived noise.
- We specifically recommend against locating this fan in a bedroom as humans' perception of noise is far greater when the surrounding environment is quiet (such as within a bedroom at night).
- Within the attic, locating the fan near an electrical outlet or power supply can minimize the need for additional electrical work.

### Required Attic Ventilation:

It is critical that the attic be sufficiently ventilated for this fan to operate properly. Without adequate ventilation, hot air cannot easily escape from the attic, which creates back-pressure that can substantially reduce the fan's performance. Specifically, operating this fan in an attic with less net free ventilation area than recommended will decrease its airflow and energy efficiency.

Whole House Fan Model	<a href="#">Lift-Lock or Ventura 1700</a>	<a href="#">Liftlock or Ventura 2500</a>	<a href="#">Sierra or Ventura 3200</a>	<a href="#">Sierra or Ventura 3400</a>	<a href="#">Sierra or Ventura 5300</a>	<a href="#">AirScape X9</a>	<a href="#">AirScape DVS 5.0</a>
CEC Required Minimum Net Free Vent Area	2.3 ft <sup>2</sup>	4.3 ft <sup>2</sup>	4.3 ft <sup>2</sup>	4.6 ft <sup>2</sup>	7.1 ft <sup>2</sup>	7.1 ft <sup>2</sup>	7.1 ft <sup>2</sup>
<a href="#">AirScape</a> Recommended Net Free Vent Area	4 ft <sup>2</sup>	6 ft <sup>2</sup>	6 ft <sup>2</sup>	7 ft <sup>2</sup>	10 ft <sup>2</sup>	10 ft <sup>2</sup>	10 ft <sup>2</sup>

Venting requirements vary by fan. We recommend a minimum of 1 square feet of “net free” ventilation area per 500 cfm at a fan’s highest speed. The minimum attic venting requirements for each model of [AirScape](#)® [Sierra](#) and [Ventura](#)® whole house fan is given in the chart at above.

Net free ventilation area can be provided by any combination of [gable](#), eyebrow, roof cap, [soffit](#), or ridge vents, or any other method of ventilating the attic space. However, the openings of most vents are partially obstructed by grilles, louvers, and/or screens. A vent’s “net free” ventilation area is then the surface area of its opening minus the surface area of any grilles, louvers, or screening covering it. Different types of vents have different ratios of net free area to total area.

Manufacturers typically publish their vents net free ventilation areas and/or ratios in their products specification documents. If this information is unavailable, a ratio of 50% net free area to total area is usually a good rule of thumb. The most notable exception to this rule of thumb are ridge vents. The industry standard net free ventilation area for ridge vents is 13% of the vent’s length in feet. Thus, a ten foot ridge vent would provide 1.3 sq. ft. of net free ventilation area.

While in our experience most properly constructed homes have adequately ventilated attics, not all do. Because sufficient ventilation is so critical to this fan’s performance, it is important that the home’s existing ventilation be verified before it is installed.

Since most attics have multiple vents, often of different types, it is necessary to count each vent, noting its type and size. Apply the appropriate ratio to the dimensions of each vent to find its net free area, and sum these values to find the attic’s total ventilation. An example of how these calculations are made is given in the chart below.

Vent Type	Dimensions	Total Area (sq/ft)	Net Free Area Ratio (NFA)	Net Free Ventilation Area (= Total Area x NFA)
<a href="#">Louver</a>	24" x24"	$24" \times 24" \div 144 = 4 \text{ ft}^2$	50%	$4 \text{ ft}^2 \times 0.50 = 2 \text{ ft}^2$
Ridge	10 feet	n/a	13%	$10 \text{ feet} \times 0.13 = 1.33 \text{ ft}^2$
Round <a href="#">soffit</a>	10" diameter	$3.14 \times 5" \times 5" \div 144 = 0.55 \text{ ft}^2$	50%	$0.55 \text{ ft}^2 \times 0.50 = 0.28 \text{ ft}^2$
Total Net Free Ventilation Area				3.61 ft <sup>2</sup>

## SAFETY INFORMATION



**Some of the principles of this product's safe installation and operation are not immediately obvious. Read the following safety information before continuing further:**



- Never operate this fan without a window or door opened.
- This fan is meant for general ventilation. It has NOT been designed to ventilate particle laden and/or explosive mixtures of air.
- This fan is not for use in kitchens.
- Never force open the damper door(s), this could severely damage the actuator. **Always** depress the actuator's yellow clutch release before manually opening or closing the damper door(s).
- Before installing or servicing this fan, switch power off at the home's electrical panel to reduce the risk of damaging circuit boards, fire, electrical shock, or injury.

## HANDLING INSTRUCTIONS

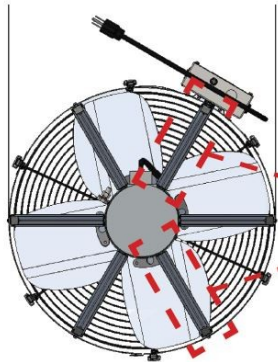

This fan's aluminum construction is corrosion-resistant and extremely durable. AirScape fans enjoy a higher efficiency than our competitors because of our [patented design](#). However, this fan should NEVER be handled using any of the Aerodynamic Wings that mount the motor within the assembly. These Wings are highlighted in the illustration. Always handle this fan by either its external casing or the motor itself. You can also handle this fan by its hanging straps, but be careful as their edges are sharp.



## SUPPLIES INCLUDED

Prior to beginning installation, please verify all of the following items were received:

- Fan Assembly, check, note serial. (see [Specifications](#) for identification of the main parts)
- PAL Door Assembly, check, note serial.
- 20" diameter x 7 feet Duct Assembly (with strap / tape kit and a fan cone for the 24 inch fan)
- Cube-Core Grille (incl. powder-coated wood screws)
- Hardware Kit (incl. screws / driver / tape / strain relief for interlock usually included in controller package)
- Digital Touch Controller package—including one Digital Touch controller, one wall mounting bracket, mounting screws and 30 feet of red shielded CAT5 cable.

Once all received parts are verified, perform an operational test BEFORE installing it in the attic. NOTE: the PAL will have to be opened and the parts removed before the test. See "[Installing the Controller](#)" and "[Start-up and Operation](#)" for connections to be made. *This is a good time to write down the serial number(s) on this IOM, which will save you a trip to the attic if you require Tech Support.*

## REQUIRED TOOL & SUPPLIES NOT INCLUDED

In addition to the included items listed above, the following tools and supplies are required to install the Whole House Fan:

- Safety Glasses, Gloves
- Receptacle tester
- Drywall Cutter
- At least 8 wood screws (1½" min. length) and washers sized to fit. (to hang the Fan)
- Cordless screwdriver with Phillips head and miscellaneous drill bits
- High quality caulk
- Lumber matching dimensions of the attic joists (e.g. 2"x6", 2"x8", etc.) and cut to fit according to the instructions in the Installation section below.
- Fishing tape or similar tool (to pull control cable through the wall)

## ELECTRICAL REQUIREMENTS

The [Ventura/Sierra](#) model WHF requires a 120 volt, Single Phase, 60 Hz, 15A uninterrupted power supply. These specifications must be taken into account when allocating power from existing circuits. We strongly recommend providing a dedicated circuit.

**This Circuit MUST be Ground Tested.** This can be done easily using a receptacle tester available at most hardware stores. This fan has a factory-installed, 20 ft. power cord. Consider this length when choosing a location for this fan. Depending on the location of existing outlets in the attic, the installation of an additional outlet may be required. *NOTE: if a GFCI is used it MUST be a Motor Rated GFCI*

All wiring and connections must be made according to this manual and acceptable wiring standards. All local codes must be followed. Consult an electrician if necessary.

## SYSTEM INSTALL GUIDE

The [AirScape](#) Whole House Fan is going to be placed in the attic, residing in an area not easily accessed. The only parts in the living space are the grill and the Digital Touch Controller. It is wise to "plan" and document your Whole House Fan Installation.

Pay particular attention to where the Door Assembly fits. Make sure the door assembly and duct work FIT in the space you selected on the framing in your attic and that the CUT you have to make in the ceiling is in a desired position in the living space. You may want to pay attention to the aesthetics or look of the living space components.

The Door Assembly position within the attic will determine the area in which the fan will be hung because of the length of the duct. Take time to determine where the fan goes and make sure the duct is loose enough to properly route it.

Pay attention to where the fan would go, where is there a power receptacle within reach of the fan's 20 foot power cord and is there enough clearance for the fan to exhaust properly. It would be great if you did not need an electrician to install Your Whole House Fan. (All dimension can be taken from the units as shipped to you, or see [Specifications](#))

**NOTE: DO NOT INSTALL THE DTC CONTROLLER NEXT TO HOME AUTOMATION DEVICES (nest etc.)! IF YOU PURCHASED A REMOTE MAKE SURE YOU MOUNT THE RECEIVER!**

**If the Door Assembly has to be installed in a wall or slanted roof, please note the orientation limitations of the door assembly you purchased.**

The [Ventura](#) WHF with an Air-Door must be orientated with the length of the door up, furthermore DO NOT exceed a 40 degree angle. It should be noted that any other orientation will prevent gravity from closing the doors properly.



INDEX

### Frame in the opening yourself:

First, using appropriately sized lumber (e.g. 2" x 6", 2" x 8", etc.) cut to fit, frame in a rough opening from the living space into the attic as shown below. Cut out the drywall inside of the framing to create the rough opening. Best method is to drill holes in the inside corners of the created framing and then saw out the piece from the living space. Clean-up can be

made much easier by using a tarp and/or box to catch the falling debris.

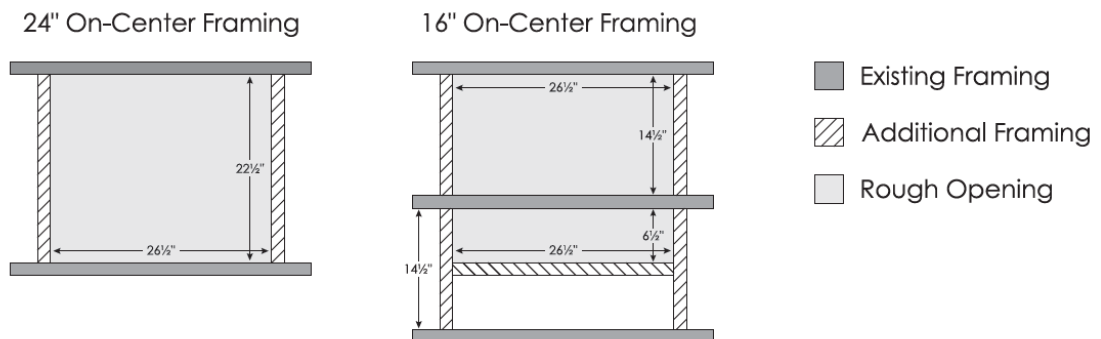

**If your home's framing is 16" on-center, the AD26 will just fit through the rough opening created above and the fan's cone must be installed in the attic.** Additional framing will also be needed. To install the Air Door on 16" framing, use appropriately sized lumber to create a "box" with interior dimensions of 22½" × 26½". Mount this "box" atop the rough opening as shown below. The Air Door installs within this "box."



If your home's framing is 16" on-center, a notch will need to be cut in the Grille in order to accommodate the center joist running across the opening, as shown at right.

**DO NOT CUT THE CENTER JOIST ITSELF.**

*NOTE: A REMOVABLE GRILLE WILL NOT WORK ON 16 O/C FRAMING.* Due to the 1" panel slot inside the removable grille. **(do not cut framing)**



To ensure that all air drawn in by the fan will be from inside the house, use a good quality latex caulk to seal all wood-to-wood and wood-to-metal joints to create an air-tight enclosure.

## INSTALLATION OF THE AIR DOOR (AD26)

**NOTE: IF YOU PURCHASED A REMOVABLE GRILLE PLEASE NOTE THAT THE AIR-DOOR MUST BE MOUNTED HIGHER INTO THE CUT OPENING TO FACILITATE OPENING THE GRILL.**

The Air-Door 26 will come as a package which includes the mounting brackets, grille and the control package. Remove the AD from it's box and remove the parts. The Air-Door can be installed directly into the opening by mounting the AD26 from below by screwing the mounting screws (included) directly through the skirt of the AD26 into the framing.

Or you can use the include mounting brackets as shown.

**DO NOT OVER-TIGHTEN THE SCREWS!**

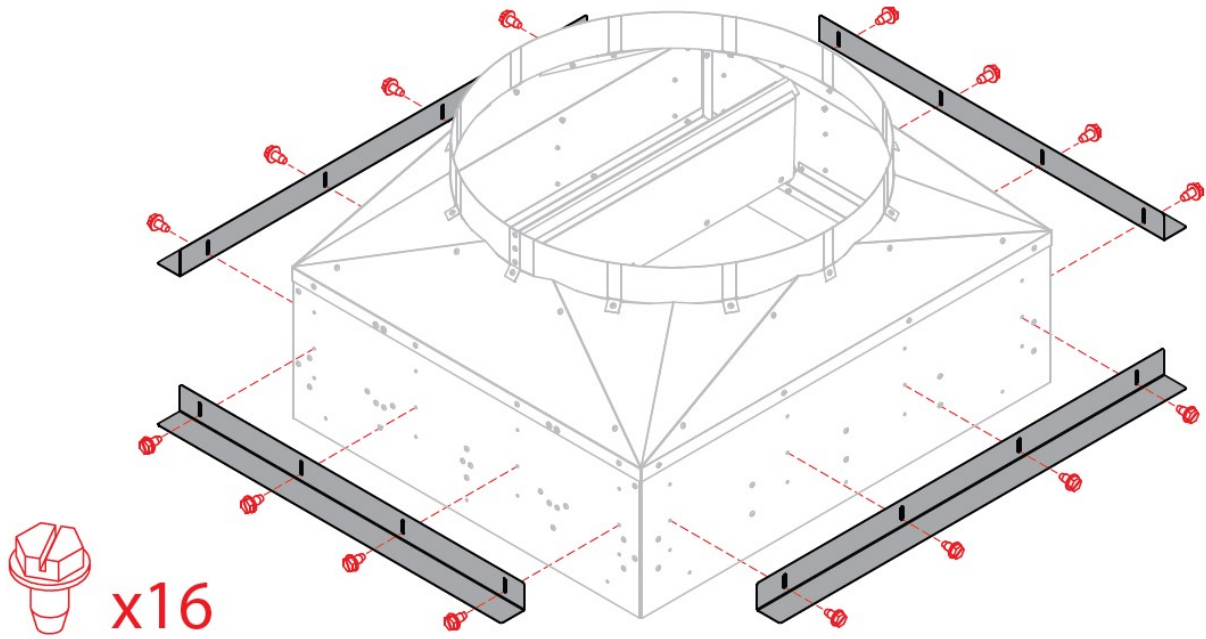

The AD26 installs directly onto the framing with the mounting screws provided. To ensure that all air drawn in by the fan will be from inside the house, use a good quality latex caulk to seal all wood-to-metal joints to create an air-tight enclosure.

INDEX

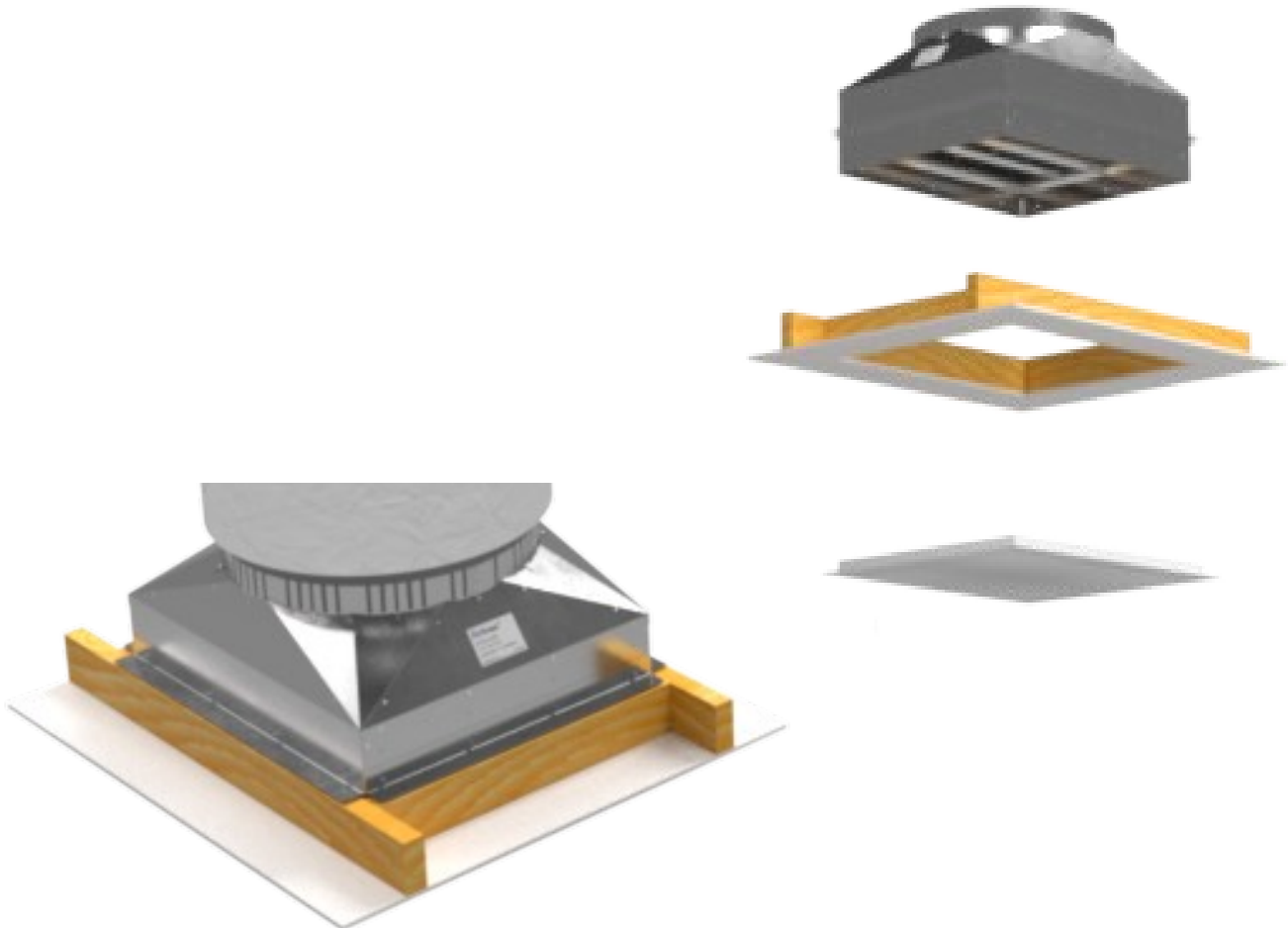

# INSTALLATION OF THE DUCT

The acoustical duct connecting the Fan to the Air-Door comes with a conical and collar connection. In order to install the duct, the mating Fan Cone must first be installed (included in the duct box).

**Careful sharp edges!** The Fan Cone is installed to the back of the fan with six bolts and must be inserted within the fan case and clamped between the steel brackets and aluminum outer clips (see image below) and held in place by six bolts. The duct connects to the cone with six quick clips

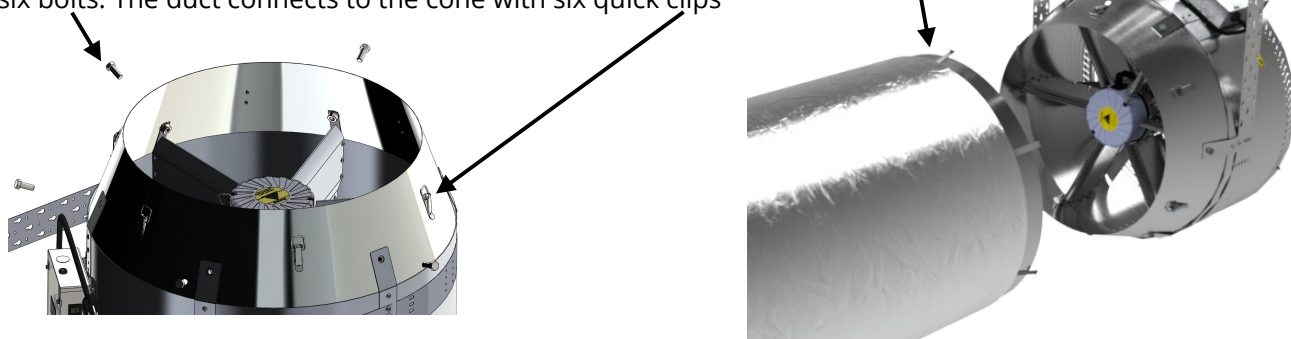

Route the duct to the Air-Door. The other end of the duct (straight collar) connects to the AD26 flange. Make sure the duct is relaxed and untwisted before you secure it in place with the 5 self drilling sheet metal screws supplied with the duct kit.

Mount the fan to the framing with screws or lag bolts (not included) in such a manner that the duct is relaxed and can be routed as shown in the image here. The routing of the duct can have a noticeable influence on the airflow.

Use the included black strap to hang the duct bend in such a manner that the duct is well supported and fully open in the bend. Roll the end of the strap a few times and screw the wrap to the rafters. The routing and mounting of the duct and strap can noticeably influence the airflow, strive for a duct that looks like the image. Use the provide aluminum butyl tape to seal the fan cone to the fan and to the duct.

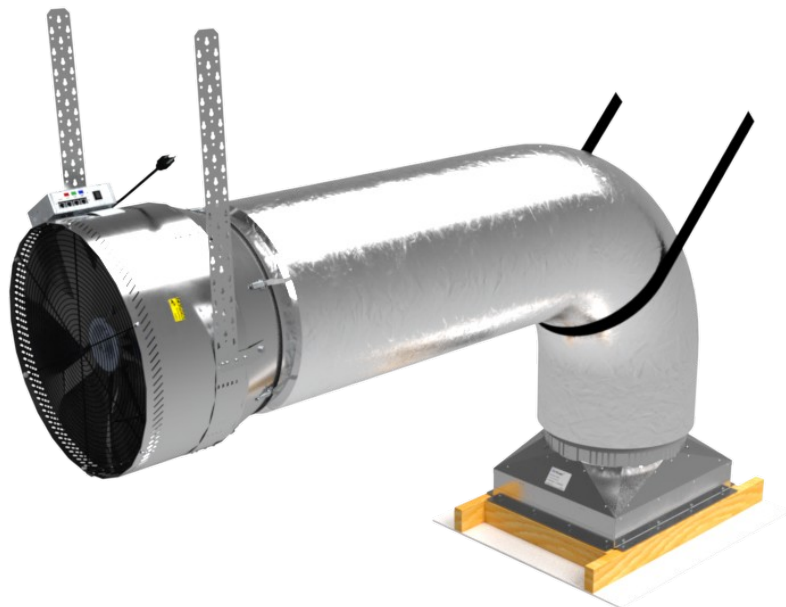

The cube-core grille is installed from within the living space after the fan, duct, and AD26 have been installed in their final location. From beneath the rough opening, first, use a high-quality latex caulk to seal all wood-to-wood and wood-to-metal seams within the space formed by the AD26 and framing. Next, mount the grille to the framing using the white wood screws provided. Hold the grille in place and mark

the mounting holes. We strongly recommend pre-drilling (undersized) holes in the framing for these screws; be careful to prevent them from stripping (DO NOT OVERTIGHTEN).

## INSTALLATION OF WIRING AND CONTROL



**The Digital Touch Controller provided with this fan is necessary for operating it, and must be connected to it regardless of whether the controller will be installed in a wall. This fan will not function if not connected to a digital touch controller!**



If it is not desired to be installed in a wall, the controller can be connected to the fan and kept in the attic with the shielded CAT5 cable kept spooled. **Note: you will need a remote to operate it.** The WebNode option (when available) may also be used to operate the system. The standard control package included with this fan contains 1 wall-mounted Digital Touch Controller plus screws; 1 mounting bracket for the controller; and 30 ft. of Red Shielded CAT5 cable.

**NOTE: DO NOT INSTALL THE DTC CONTROLLER NEXT TO HOME AUTOMATION DEVICES (nest, etc.)!**

First, locate the desired location for the Digital Touch controller. Install the mounting bracket according to figures A–C below. Return to the attic and connect the red CAT5 cable to the RJ45 port on the control box labeled W/S (red). Run this cable from the control box to the location of the controller. NOTE: this is a low-voltage cable, **DO NOT RUN IT PARALLEL TO HIGH-VOLTAGE WIRING**; building codes generally require low-voltage cable to be run through shielded conduit.

**NOTE: Carefully unwind and run the CAT5 Cable down the wall, AVOID kinks as this can damage the Cable conductors!**

Connect the CAT5 cable to the RJ45 port on the back of the Digital Touch controller. Mount the controller to the mounting bracket with the provided white screws, DO NOT over-tighten (figure D).

Fig. A:

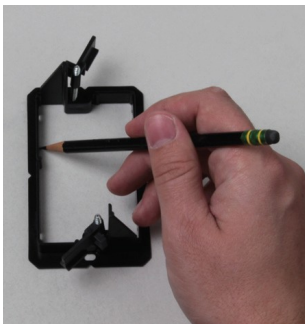

*Use the mounting bracket as a template to mark the hole location*

Fig. B:

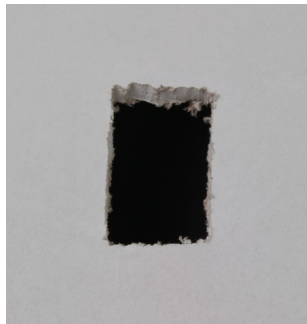

*Cut out the hole*

Fig. C:



*Place the mounting bracket and secure its locking tabs by tightening the silver screws*

Fig. D:



*Connect the CAT5 cable. Mount the DTC to the bracket with the provided white screws*

All wiring connections to the fan assembly are made at the fan-mounted electrical box. These are a 20 ft, black, factory-installed power cord, a 10 foot actuator power harness and three RJ45 (“Ethernet”) ports for connecting the fan controls and accessories (see below) Color Match Cable and Jack Identification

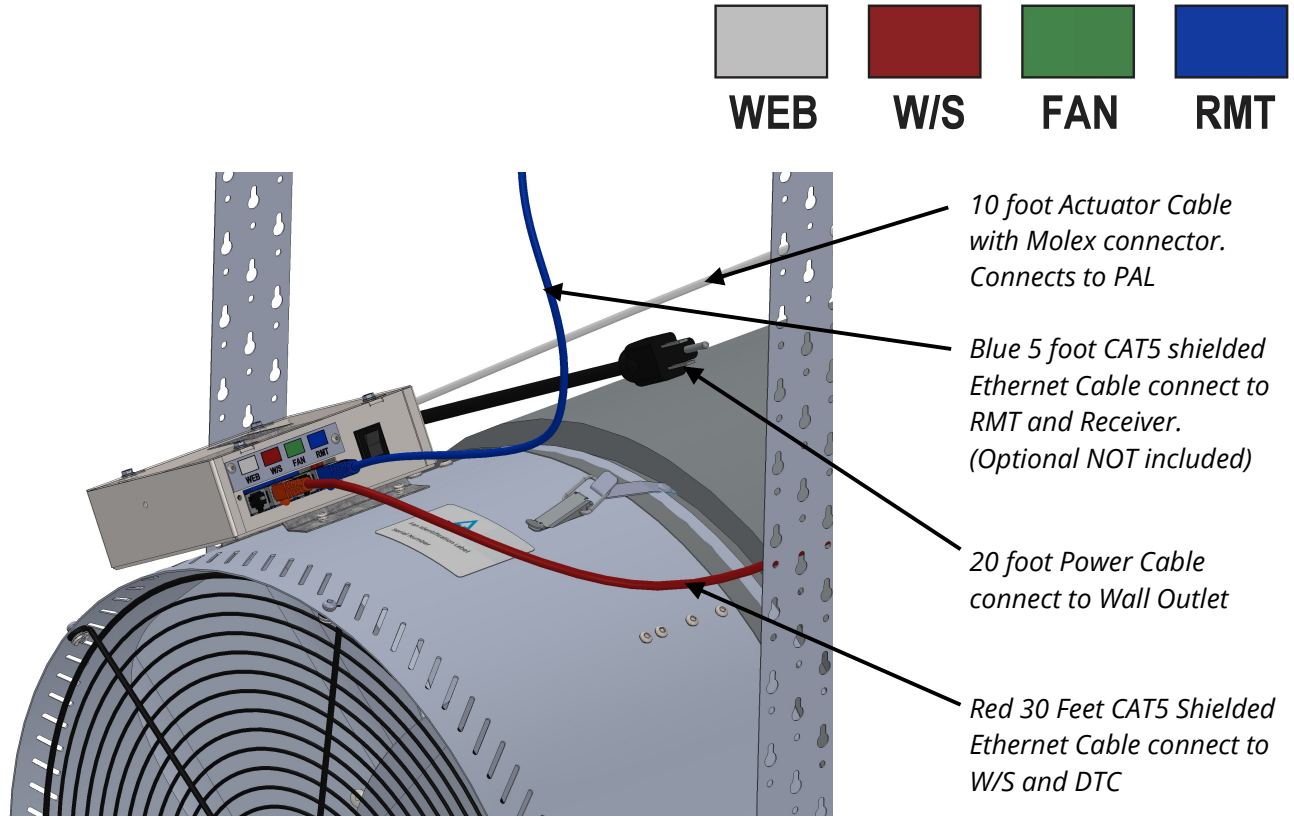

Note: The “WEB” port is not available yet but can be upgraded at a later time.

## PURCHASE OPTIONS

A wireless remote is an available [accessory option](#) for this fan. The wireless remote is NOT included as part of this fan’s standard control package. The yellow manual included with these accessories provides specific instructions for the installation and operation of the remote. If purchased, the wireless remote receiver is connected to the fan-mounted electrical box at the blue RMT RJ45 port. (see above)

An acoustical plenum (ACP2) and a removable grille (ONLY FOR 26 O/C FRAMING) are other available [accessory options](#).

A Web Node is another option not included in the standard WHF package. This will allow you to control your fan using your mobile phone or tablet or home automation device through a web page or an app. The Web Node comes with a white cable and connects the Web Node to the WEB port. (see above) The yellow manual included with these accessories provides specific instructions for the installation and operation of the Web Node. Note: The “WEB” port is not available yet but can be upgraded at a later time.

## START-UP AND OPERATION

Before starting this Fan for the first time, verify that:

- All wiring and connections have been made according to this manual and acceptable wiring standards, and that this manual and all local codes and standards have been followed in this fan's installation.
- No tools or construction debris have been left in, on, or around the fan.
- The fan's power cord has been plugged into a ground tested, 120-volt outlet with uninterrupted power.
- The area in front of the fan's outlet is as unobstructed as possible, with no object closer than 24" to the face of the fan.

When running this fan for the first time, make sure to observe it turning on, running at all of its speed settings, and turning off. Observe from both the attic (to observe the fan(s) itself) and the living space (to observe its damper door(s)), also verify Timer works at 1 Hour Setting.

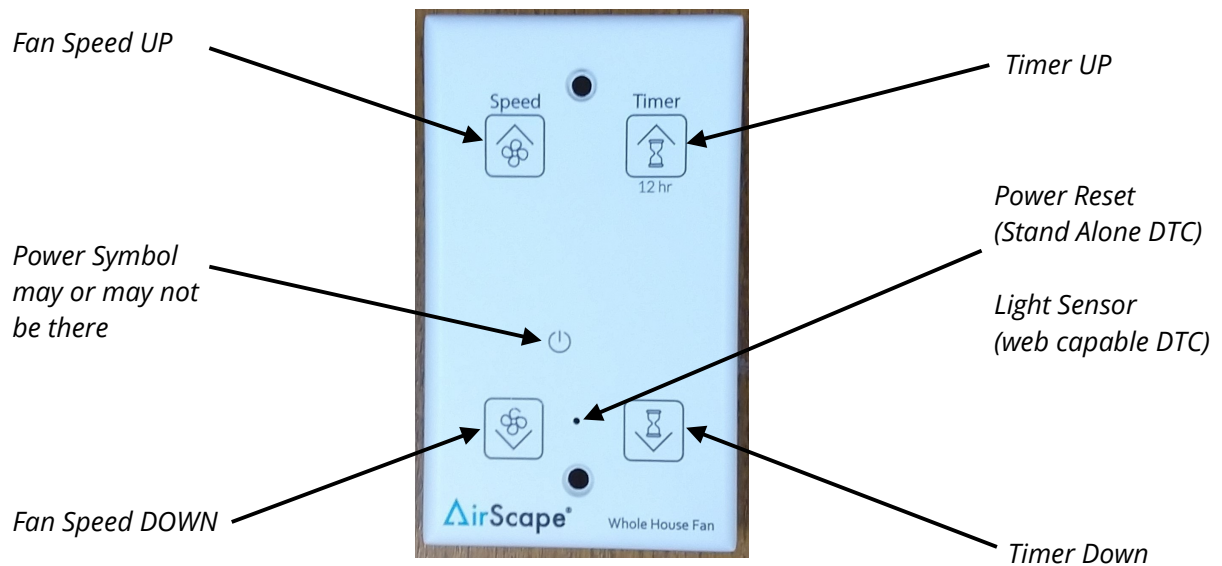

**As shown, there are four buttons on your fan's control interface:**

The AirScape WHF has ten speed settings. Turn on the Fan by touching FAN UP or TIMER UP. Its door(s) will open by the airflow the fan creates. The fan will start at minimum speed. Green LED's will illuminate to indicate the speed setting.

Note: there is no delay on a unit with gravity doors.

If the Fan was turned on by TIMER UP, the timer will be set to one hour and blue LED's will illuminate to indicate the timer setting. Press or hold FAN UP to increase the fan's speed to maximum. Press or hold TIMER UP to increase the length of time the Fan stays on in one hour increments until the desired time, or the maximum time of 12 hours, is achieved.

If the fan is already operating at minimum speed, touch FAN DOWN/OFF to turn off the fan; any time remaining on the timer will be canceled. If the fan is at maximum speed, press or hold FAN DOWN/OFF to decrease the speed to minimum and once again to turn the fan off.

Press or hold TIMER DOWN/CANCEL to reduce the time on the timer by one hour increments until the desired time is achieved or the timer is canceled. When the timer expires, the fan will turn off automatically. If the timer is canceled, the fan will remain on at its current speed.

Whenever the fan is turned off, its damper door(s) will close tightly within about 60 seconds.

\* Note: If untouched after a moment the selection LED's will dim.

## OPERATING TIPS

- Never operate your whole house fan without also opening a window or door. Doing so can excessively depressurize your home.
- Only operate your whole house fan when the outdoor air temperature is cooler than the indoor temperature.
- Make sure your air conditioner and furnace are off before you turn on your whole house fan. Running either of these together with your whole house fan wastes energy and money because the fan will force expensively conditioned or heated air out of your home.
- Use your whole house fan's higher speed settings to cool your home quickly in the evening. Then, switch to its lower settings to run it quietly and efficiently through the night.
- We recommend you run your whole house fan through the night. Here's why: The goal of using a whole house fan is to cool your entire home, not just the air inside it. Once heated, your home's structure and contents continue to radiate heat until reaching the temperature of the surrounding air. By running your fan through the night, you speed up this cooling process and can then further "pre-cool" your home, reducing or eliminating the need to use air conditioning the next day. AirScape fans are extremely efficient, so operating your fan in this way is very inexpensive, especially compared to the cost of air conditioning.
- If your home has a basement, extra cooling can be achieved by drawing in air through the basement windows.
- You can control where your fan's cooling effect is concentrated by adjusting the location of the windows you open. Visualize the path air will travel from the windows to your fan's opening. Generally, the longer the path, the more cooling.

# DIGITAL TOUCH CONTROLLER – DTC

Although your DTC should arrive with all the proper settings for the system you purchased we include this information.

The function of the Digital Touch Controller is dependent on the configuration of the DIP switches and pin jumper located on the back of the PCB. The jumper pins are located to the left of the RJ45 port, and the DIP switches are immediately below it.

The jumper is configured by placing it to connect two of the three pins, as shown (pin 1-2). \*



The DIP switches are configured by switching them to the ON or OFF position, depending on the switch number. A DIP switch in the ON position is set away from its number, and towards the side labeled ON, as shown.



MODEL	JUMPER SETTING	DIP SWITCH SETTING
N/A Any unit with actuated doors requires a delayed fan start. (time delay) PAL – Powered Air-Lock / LL - Lift-Lock	Pin 1-2* (24VDC PWM)	1: ON 2: OFF 3: OFF 4: ON  (time delay**)
<b>Ventura 3400 / 5300</b> AirScape Fan with Gravity Doors (AD26) Units with gravity doors (Air-Doors) can be started directly (no time delay)	Pin 1-2* (24VDC PWM)	1: ON 2: OFF 3: OFF 4: OFF  (direct start)

\* Pin 1-2 = 24VDC PWM Motor speed control/ Pin 2-3 = 0 – 10 VDC Motor speed control.  
Most fans have a PWM controlled motor.

\*\* Time delay allows the door(s) to open before the fan starts

Rear View of the Digital Touch Controller

RJ45 Jack

Speed Control Format Jumper

Dip Switch

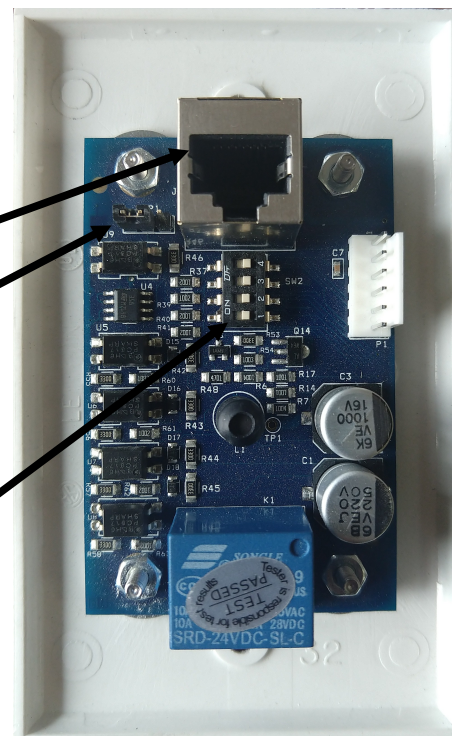

INDEX

# FAN BOX BOARD

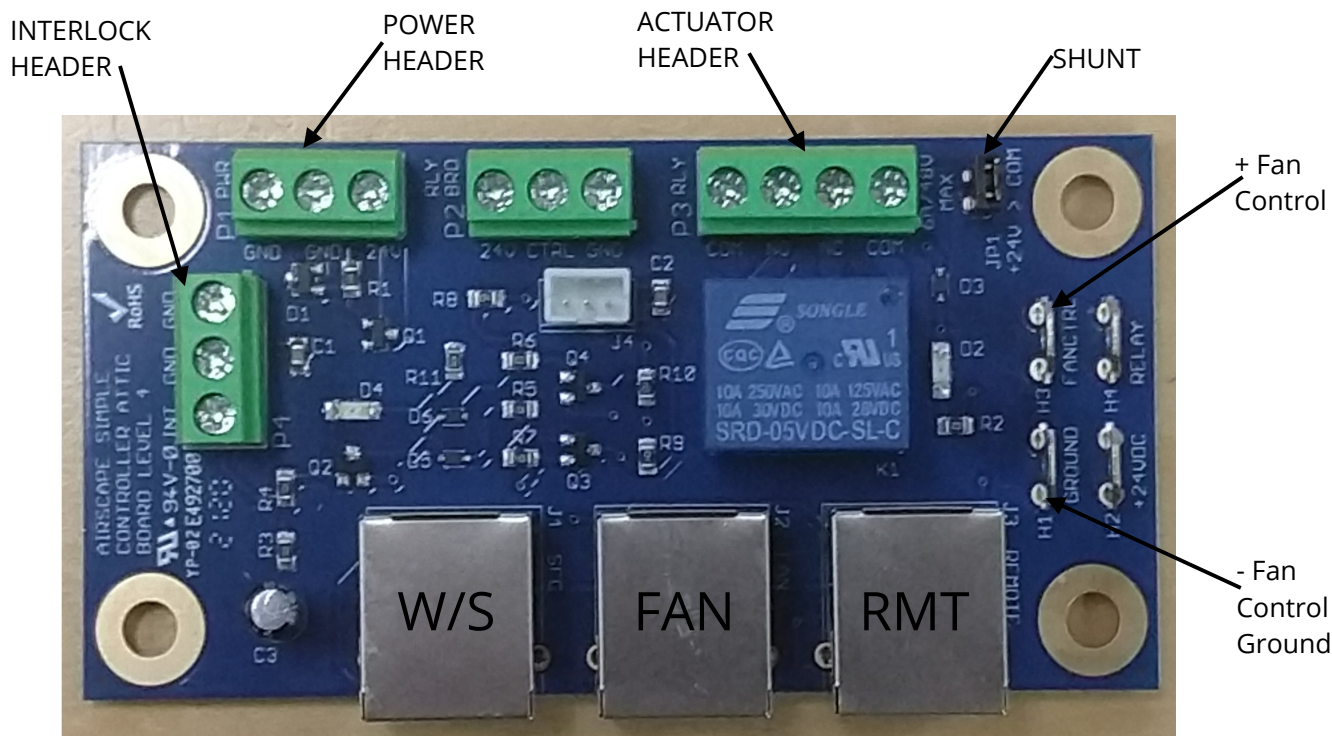

There is quite a bit of white text on the board, labeling these connections.

The Actuator Relay (door) has 24VDC on the COM terminals (JP1=shunted). This provides power to the actuators (not applicable to the Ventura Line).

Fan speed control signals can be put out in both formats and are chosen on the DTC (JP1, see DTC above). On this fan board (SCAB) the motor control wiring is connected to two spade connectors. The negative = "Ground" spade and the positive = "Fan Cntl" Spade.

The Red LED D4 comes on with power to the board and the Red LED D2 comes on when the controller calls for a fan start and activates the doors (fan will start after a 10 second delay if selected)

### Interlock:

This allows you to disable operation of the unit while other appliances are active, such as heating or cooling systems. While triggered, this interlock disables the fan and sets the damper doors to the Off position, but does not reset the current fan speed as displayed on the Digital Touch controller. Removal of the interlock allows the unit to resume the previously set fan speed. The Timer function will continue to operate normally while the interlock is active.

It is important that **no voltage** be sent to the board from external sources when choosing how to wire this interlock. It is designed to operate only as a closed loop circuit. This interlock is controlled with the INT and GND contacts on terminal block P4, on the SCAB. This board is found inside the junction box mounted on the fan unit.

This interlock is triggered by closing the circuit between two contacts on the board. The exact method of closing this circuit will depend on the particular installation and equipment the controller is interfacing with. One possible way of doing so is with a double-pole wall switch, in which it is wired so that one pole is used to control power to the appliance and the other pole closes the interlock contacts. Another way would be to use a relay or current switch that is activated when the appliance is turned on. Fire Alarm may call for the "InterLock" as well

## MAINTENANCE

There is no routine maintenance required for the Fan other than making sure the Fan and its damper door(s) remain clear of dust or debris, and that the area in front of the Fan remains as unobstructed as possible, with no object closer than 24" to the face of the Fan.

We however advise that you check the operation of the doors and fan at the start of each season and remove any insulation panels in the removable grille if you purchased such an option. If the Air-Door 26 door plates are sticking to the foam (due to excessive heat) apply talcon powder to the seals surfaces

A re-settable circuit breaker is located on the Fan-mounted electrical box to protect circuit boards from power surges. In the case of a power surge, this breaker can be reset by simply pushing the button back in.

## GLOSSARY

AD: Air-Door, a gravity door made to seal well and open with little effort includes framing (latest versions), requires a grille

CEC: California Energy Commission.

CFM: Cubic Feet per Minute.

dBA: Decibels A is a noise level measured in decibels (dB) 60dBA is considered conversation level noise.

DTC: Digital Touch Controller

DVS: Direct Venting System.

GFCI: Ground Fault Circuit Interrupter, for systems using a motor use a **Motor Rated GFCI**.

Hz: Hertz equals the number of cycles per second (alternating currents)

LL: Lift-Lock™ Actuated insulated door installed from the living space (no grille)

O/C: On Center, indication of framing distance between beams measured in the center of the beam.

PAL: Powered Air-Lock™ Actuated Door(s) usually insulated, requires a grille

PSU: Power Supply Unit.

PWM: Pulse Width Modulation is used for controlling the amplitude of digital signals in order to control motor speed or other devices.

SCAB: Simple Controller Attic Board or Fan Box Board (located on the fan)

VA: Volt-ampere (VA) is a measurement of power in a direct current (DC) electrical circuit 1 VA = 1W

VAC: Volts Alternating Current.

VDC: Volts Direct Current.

WHF: Whole House Fan a ventilation system intended for cooling the entire house.

## TROUBLE SHOOTING



***Before servicing your whole house fan, turn off power to it at your home's electrical panel to reduce the risk of electrical shock, injury, fire, and/or circuit board damage.***



Your AirScape Fan has been factory tested. If you encounter problems with the unit, please take a few minutes to run through the following troubleshooting procedures **before calling for technical support.**

### **NOTE:**

***A "kinked" CAT5E Cable may cause all of the listed symptoms. Use a second short cable and plug the wall switch (controller) directly into the W/S port on the fan to rule out a cable issue before proceeding.***

*A re-settable circuit breaker is located on the Fan-mounted electrical box to protect circuit boards from power surges. In the case of a power surge, this breaker can be reset by simply pushing the button back in.*

### **Symptom: Unit does not start**

Possible causes: No power to unit or kinked Ethernet Cable

Suggestion 1: Open Fan Box, is the power LED on the SCAB\* on?

Reset main Power (unplug, wait 10 sec., plug in).

Suggestion 2: Check the re-settable circuit breaker on fan's electrical box.

Suggestion 3: Take DTC\*\* into the attic and connect it to the W/S port using another CAT5 Cable.

Suggestion 4: Check power (115VAC) at the electrical outlet, inside the fan's electrical box wiring at both the power supply (115VAC) and the SCAB\* (24VDC inside the fan's electrical box).

Suggestion 5: Check for pwm (control 0-24VDC, 80Hz PWM) signal at fan's control wire connections on the SCAB\* this can be done using a volt meter set to dc but gives approximate values.

\*\* DTC = Digital Touch Controller

\* SCAB = Simple Controller Attic Board / Fan Box Mounted Board

### **Symptom: Wireless remote does not Operate.**

Possible causes: Battery, RF interference.

Suggestion 1: Check transmitter's battery for power. Replace if necessary, NOTE: POLARITY.

Suggestion 2: Check to see if LED on the remote receiver is lit. Open the cover and see if the internal LED's respond by pressing a button on the remote.

Suggestion 3: Temporarily replace the CAT5 Ethernet cable with another cable.

Suggestion 4: Check for red LED response on DTC (stand alone only) when pressing the remote buttons.

### **DTC trouble shooting**

*When the Digital Touch Controller (DTC) is connected to the fan, and the fan to power, a red LED will illuminate on the face plate (Stand Alone only). If the Power Indicator is not illuminated; double-check the connections between the fan and the controller, between the fan and the power outlet and power at the outlet.*

***If problems are encountered, please take a few moments to run through the troubleshooting procedures described on the blue Warranty Card. If these suggestions do not work, contact AirScape technical support at [1.866.448.4187](tel:1.866.448.4187) or by email at [experts@airscapefans.com](mailto:experts@airscapefans.com) for further assistance.***

**NOTE: You will be asked for the serial numbers of the Fan and PAL.**

# SPECIFICATIONS

<b>Dimensions Fan:</b>	Ø 24.75" × 14"
<b>Fan Cone:</b>	Yes
<b>Weight Fan:</b>	40 lbs
<b>PAL26:</b>	33.6"L x 26.3"W x 19.3"H
<b>Weight PAL26:</b>	53 lbs
<b>Acoustical Duct:</b>	Ø 20" x 7 foot long
<b>Duct Weight:</b>	11.5 lbs
<b>Tested Airflow*:</b>	3400 = 225 / 3342 CFM 5300 = 15 / 5497 CFM
<b>Tested Power*:</b>	3400 = 15 / 292 Watts 5300 = 16.9 / 902 Watts
<b>Tested Noise**:</b>	3400 = 36 / 52 dBA 5300 = 36 / 68 dBA
<b>Rough Opening:</b>	22.5"W × 26.5"L
<b>Electrical:</b>	120 VAC, 60 Hz, 15 A
<b>Installation:</b>	16" or 24" O/C joists
<b>Controls:</b>	Low Voltage, Digital Touch Controller optional wireless remote
<b>Speed Settings:</b>	10
<b>Warranty:</b>	3 years parts, 1 years controls

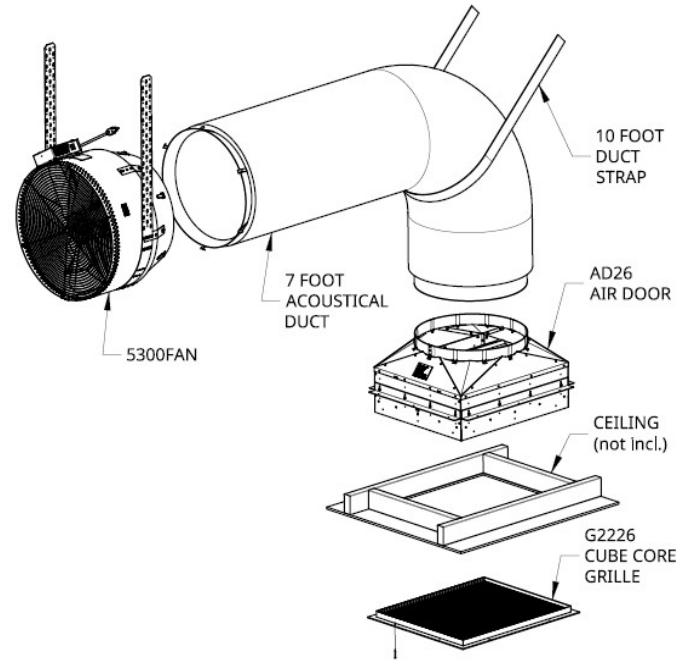

INDEX

\* Actual performance will vary from installation to installation.

\*\* Tested at 45° and 1 meter from the grille.

**Due to continual product improvement, performance ratings and specifications are subject to change without notice.**

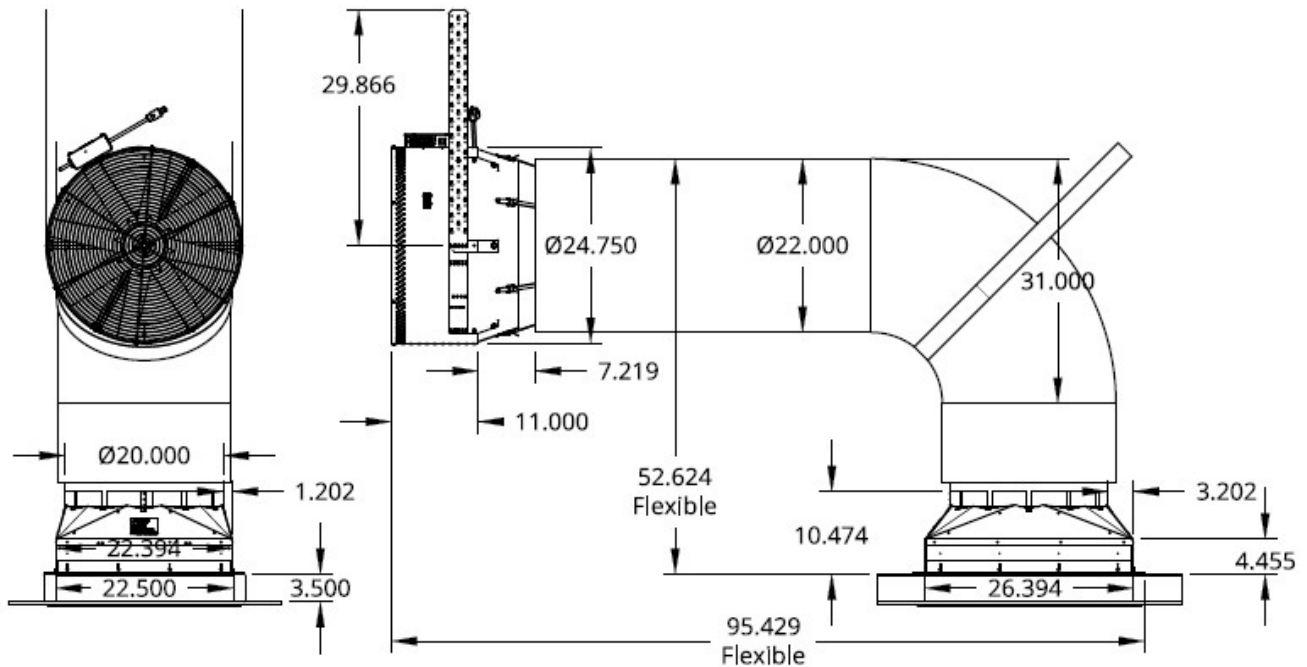

## AIRLAB RESULTS

### VENTURA 3400

Fan Setting	Power (Watts)	AirLab Airflow (CFM)	Efficiency (CFM per Watt)	Sound Level @ Inlet (dBa) (test room @ 36dBa)
1	15	225	15	36
2	22.7	409	18.02	37
3	45.8	1114	24.32	39
4	72.4	1794	24.78	40
5	102	2162	21.2	42
6	137	2554	18.64	47
7	172	2783	16.18	48
8	210	2994	14.26	49
9	250	3192	12.77	50
10	292	3342	11.45	52
<b>High Efficiency</b> High Efficiency Range, Low Harmonic Range				

### VENTURA 5300

Fan Setting	Power (Watts)	AirLab Airflow (CFM)	Efficiency (CFM per Watt)	Sound Level @ Inlet (dBa) (test room @ 36dBa)
1	16.9	15	0.89	36
2	30	954	31.8	39
3	53.9	1713	31.78	44
4	94.9	2358	24.85	50
5	159.9	2943	18.41	52
6	250	3482	13.93	55
7	378	4075	10.78	60
8	554	4650	8.39	64
9	781	5208	6.67	66
10	902	5497	6.09	68
<b>High Efficiency</b> High Efficiency Range, Low Harmonic Range				

## AIRSCAPE 101 - RESOURCE

